

User instructions

Transmitted light laboratory microscope

KERN **OBF-1, OBL-1**

OBF 121, OBF 122, OBF 123, OBF 131, OBF 132, OBF 133
OBL 125, OBL 127, OBL 135, OBL 137

Version 1.0
01/2015





KERN OBF-1, OBL-1

Version 1.0 01/2015

User instructions

Transmitted light microscope

Table of contents

1	Before use	3
1.1	General notes	3
1.2	Notes on the electrical system	3
1.3	Storage	4
1.4	Maintenance and cleaning	5
2	Nomenclature	6
3	Technical data / Features	8
4	Assembly	11
4.1	Microscope head	11
4.2	Objectives	11
4.3	Eyepieces	11
4.4	Colour filter	11
4.5	Condenser	12
5	Operation	12
5.1	Getting started	12
5.2	(Pre-) focussing	13
5.3	Adjusting the interpupillary distance	14
5.4	Dioptre adjustment	14
5.5	Adjusting the magnification	15
5.6	Adjusting the Koehler illumination	16
5.7	Using eye cups	18
5.8	Using oil immersion objectives	19
6	Changing the bulb	20
7	Changing the fuse	21
8	Using optional accessories	21
8.1	Polarisation unit	21
8.2	Camera connection	22
8.3	Dark field units	22
8.4	Phase-contrast unit	23
8.5	Fluorescence reflected light unit	25
9	Trouble shooting	36
10	Service	38
11	Disposal	38
12	Further information	38

1 Before use

1.1 General notes

You must open the packaging carefully, to make sure that none of the accessories in the packaging fall on the floor and get broken.

In general, microscopes should always be handled carefully because they are sensitive precision instruments. When using or transporting the microscope it is particularly important to avoid abrupt movements, as this may damage the optical components.

You should also avoid getting dirt or finger prints on the lens surface, because in most cases this will reduce image clarity.

To maintain the performance of the microscope, it must never be disassembled. So components such as lenses and other optical elements should be left as they were before use. Also the electrical parts on the rear and base of the device must not be tampered with, as in this area there is an additional risk of triggering an electric shock.

1.2 Notes on the electrical system

Before connecting to a mains power supply, you must make sure that you are using the correct input voltage. The information to select the correct mains cable is located on the device, on the rear of the product directly above the connection socket. You must comply with this information. If you do not comply with these specifications, then fires or other damage to the device could occur.

The main switch must also be switched off before the mains cable is connected. In this way you will avoid triggering an electric shock.

If you are using an extension cable, then the mains cable you use must be earthed.

If the original fuse should blow, it must only be replaced by an appropriate fuse. Suitable replacement fuses are included with the delivery.

When carrying out any procedures whereby you come into contact with the electrical system of the device, such as, for example, changing the bulb or fuse, only carry out these procedures when the power is disconnected.

Under no circumstances should you touch the integrated halogen bulbs either during operation or directly after use. These bulbs produce significant heat and therefore there is a risk that the user could be severely burnt. So before handling the bulbs, you must check that they have cooled down.

The microscope housing, on the other hand, is constructed so that no significant heat radiation emanates from the device and that there is absolutely no risk of the user burning themselves from the housing outer surfaces.

1.3 Storage

You should ensure that the device is not exposed to direct sunlight, temperatures which are too high or too low, vibrations, dust or a high level of humidity.

The ideal temperature range is between 0 and 40°C and a relative humidity of 85% should not be exceeded.

The device should always be located on a rigid, smooth, horizontal surface.

When the microscope is not being used, you should cover it with the enclosed dust protective cover. When doing this, the power supply is stopped by switching off at the main switch and unplugging the mains cable. If the eyepieces are being stored separately, the protective caps must be fitted to the tube connectors. In most cases, if dust and dirt gets inside the optical unit of a microscope this can cause irreversible errors or damage.

The best way to store accessories which consist of optical elements, such as, for example, eyepieces and objectives, is in a dry box with desiccant.

1.4 Maintenance and cleaning

In any event, the device must be kept clean and dusted regularly.

If any moisture should occur, before you wipe down the device you must ensure that the mains power is switched off.

When glass components become dirty, the best way to clean them is to wipe them gently with a lint-free cloth.

To wipe oil stains or finger prints off the lens surface, moisten the lint free cloth with a mixture of ether and alcohol (70 / 30 ratio) and use this to clean the lens.

You must be careful when handling ether and alcohol, as these are highly flammable substances. You must therefore keep it away from naked flames and electrical devices which can be switched on and off, and only use it in well-ventilated rooms.

However organic solutions of this type should not be used to clean other components of the device. This could lead to damage to the paint finish. To do this, it is sufficient to use a neutral cleaning product.

You could also use the following cleaning products to clean the optical components:

- Special cleaner for optical lenses
- Special optical cleaning cloths
- Bellows
- Brush

When handled correctly and checked regularly, the microscope should give many years of efficient service.

Should repairs still be necessary, please contact your KERN dealer or our Technical Department.

2 Nomenclature

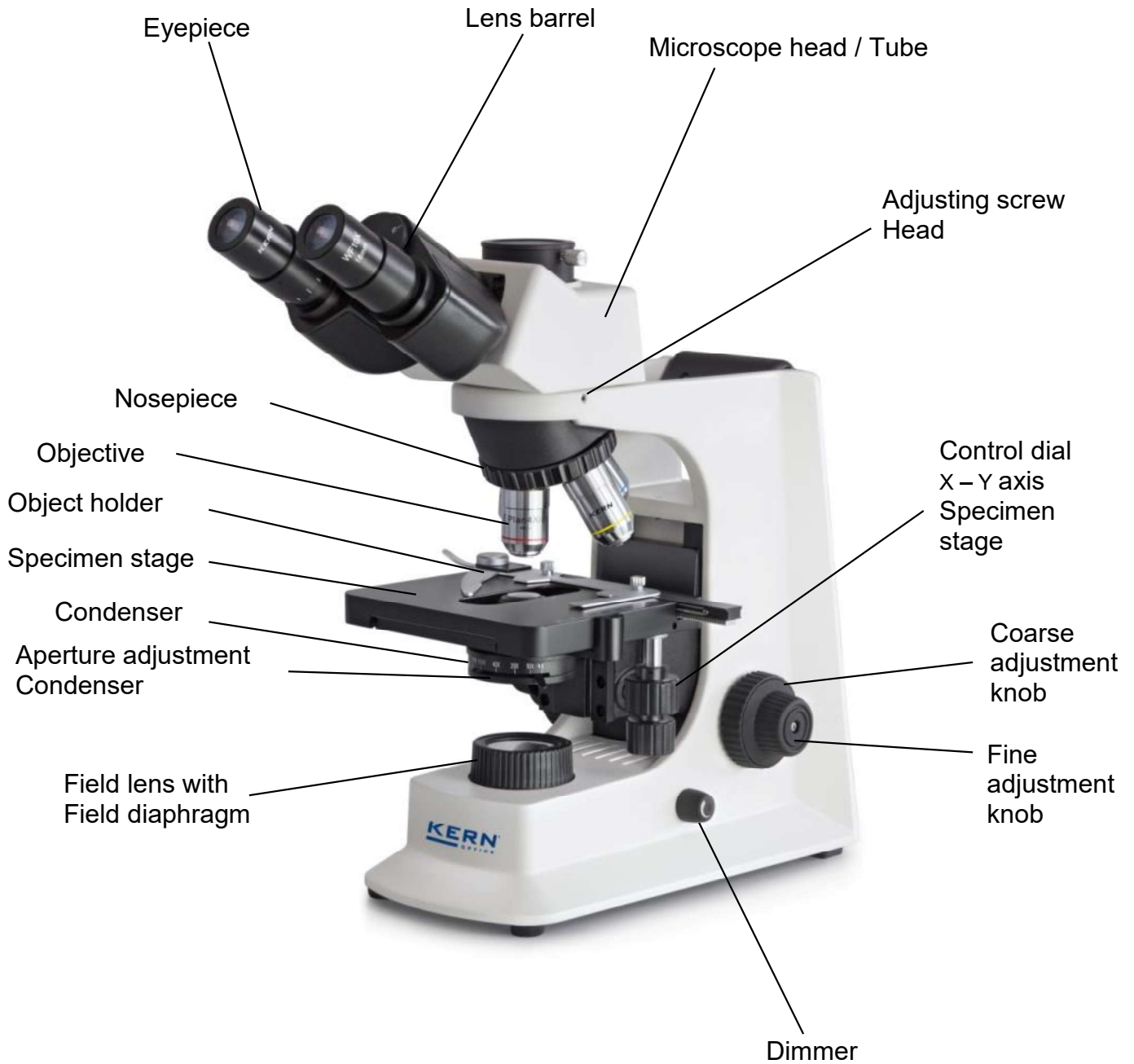

Rear view

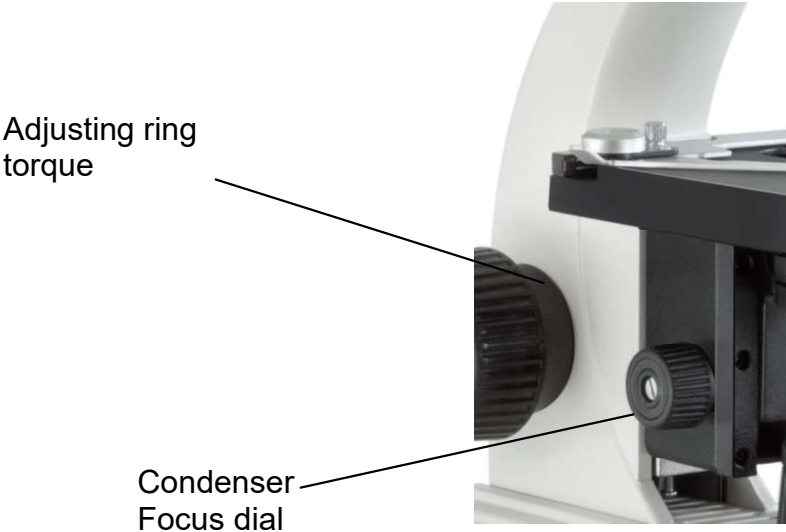
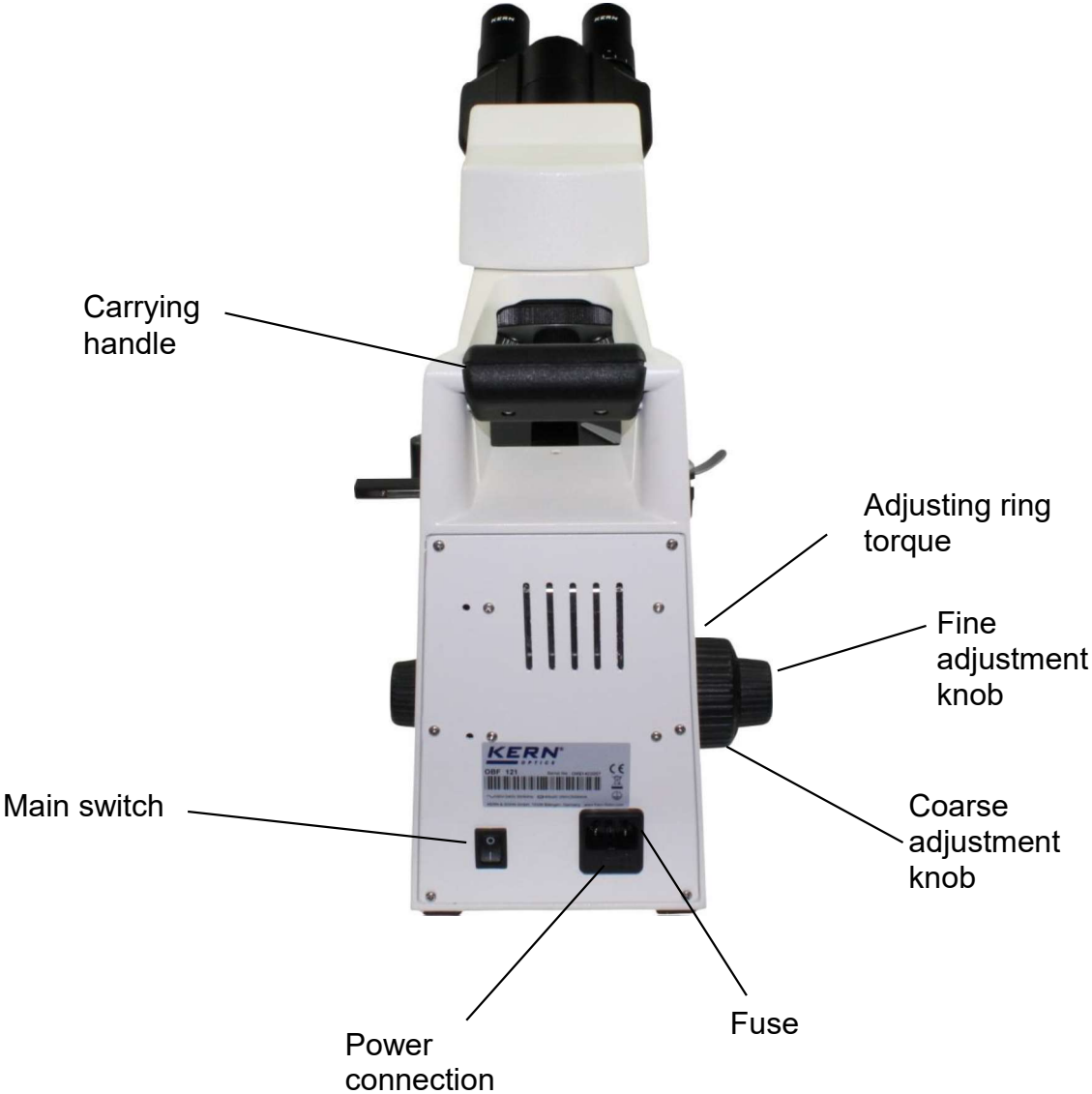

3 Technical data / Features

Model	Standard configuration		
	Optical system	Tube	Illumination
KERN			
OBF 121	Finite	Binocular	6V / 20W Halogen (Transmitted light)
OBF 122	Finite	Binocular	6V / 20W Halogen (Transmitted light)
OBF 123	Finite	Binocular	3W LED (Transmitted light)
OBF 131	Finite	Trinocular	6V / 20W Halogen (Transmitted light)
OBF 132	Finite	Trinocular	6V / 20W Halogen (Transmitted light)
OBF 133	Finite	Trinocular	3W LED (Transmitted light)
OBL 125	Infinity	Binocular	6V / 20W Halogen (Transmitted light)
OBL 127	Infinity	Binocular	3W LED (Transmitted light)
OBL 135	Infinity	Trinocular	6V / 20W Halogen (Transmitted light)
OBL 137	Infinity	Trinocular	3W LED (Transmitted light)

Eyepieces OBF-1: WF 10x / Ø 18 mm

Eyepieces OBL-1: WF 10x / Ø 20 mm

Objectives: 4x / 10x / 40x / 100x

Product dimensions: 395x200x380 mm

Packaging dimensions: 400x280x435 mm

Net weight: 6,7 kg

Gross weight: 8 kg

Input voltage: AC 100-240V, 50-60Hz

Output voltage: DC 1,2-6V

Fuse: 2A 5x20mm

Model outfit		Model KERN						Order number
		OBF 121	OBF 131	OBF 122	OBF 132	OBF 123	OBF 133	
Eyepieces (23,2 mm)	HWF 10×/∅ 18 mm	✓✓	✓✓	✓✓	✓✓	✓✓	✓✓	OBBA1403
	WF 16×/∅ 13 mm	○○	○○	○○	○○	○○	○○	OBBA1354
	HWF 10×/∅ 18 mm (with Pointer)	○	○	○	○	○	○	OBBA1348
	HWF 10×/∅ 18 mm (reticule 0,1 mm) (non-adjustable)	○	○	○	○	○	○	OBBA1349
Achromatic objectives	4×/0,10 W.D. 18,6 mm	✓	✓					OBBA1111
	10×/0,25 W.D. 6,5 mm	✓	✓					OBBA1108
	40×/0,65 (spring) W.D. 0,47 mm	✓	✓					OBBA1112
	100×/1,25 (oil) (spring) W.D. 0,07 mm	✓	✓					OBBA1109
	20×/0,40 (spring) W.D. 1,75 mm	○	○					OBBA1110
	60×/0,85 (spring) W.D. 0,1 mm	○	○					OBBA1113
Plan objectives	4×/0,10 W.D. 14,5 mm			✓	✓	✓	✓	OBBA1255
	10×/0,25 W.D. 5,65 mm			✓	✓	✓	✓	OBBA1238
	40×/0,65 (spring) W.D. 0,85 mm			✓	✓	✓	✓	OBBA1256
	100×/1,25 (oil) (spring) W.D. 0,07 mm			✓	✓	✓	✓	OBBA1239
	20×/0,40 (spring) W.D. 1,5 mm			○	○	○	○	OBBA1249
	60×/0,85 (spring) W.D. 0,07 mm			○	○	○	○	OBBA1269
	100×/1,0 (water) (spring) W.D. 0,18 mm	○	○	○	○	○	○	OBBA1441
Binocular tube	+ Siedentopf 30° inclined/360° rotatable + Interpupillary distance 50–75 mm (for non-infinity system) + Diopter adjustment: One-sided	✓	○	✓	○	✓	○	OBBA1129
Trinocular tube	+ Siedentopf 30° inclined/360° rotatable + Interpupillary distance 50–75 mm + Light distribution 20:80 (for non-infinity system) + Diopter adjustment: One-sided	○	✓	○	✓	○	✓	OBBA1345
Mechanical stage	+ Stage size W×D 145×130 mm + Travel 76×52 mm + Coaxial coarse and fine focusing knobs, scale: 2 µm + Two slide holder	✓	✓	✓	✓	✓	✓	
Condenser	Abbe N.A. 1,25 precentered (aperture diaphragm)	✓	✓	✓	✓	✓	✓	OBBA1103
Darkfield condenser	N.A. 0,85–0,91 (dry, paraboloid)	○	○	○	○	○	○	OBBA1422
Illumination	6 V/20 W Halogen spare bulb (transmitted)	✓	✓	✓	✓			OBBA1370
	3 W LED illumination system (transmitted) (non-rechargeable)					✓	✓	
Polarising unit	Analyser/Polariser	○	○	○	○	○	○	OBBA1277
Colour filters for transmitted illumination	Blue (built-in)	✓	✓	✓	✓	✓	✓	
	Green	○	○	○	○	○	○	OBBA1188
	Yellow	○	○	○	○	○	○	OBBA1165
	Gray	○	○	○	○	○	○	OBBA1183
C-Mount	0,47× (focus adjustable)		○		○		○	OBBA1135
	1×		○		○		○	OBBA1142

Model outfit		Model KERN				Order number	
		OBL 125	OBL 135	OBL 127	OBL 137		
Eyepieces (23,2 mm)	HWF 10×/∅ 20 mm	✓✓	✓✓	✓✓	✓✓	OBB-A1404	
	WF 16×/∅ 13 mm	○○	○○	○○	○○	OBB-A1354	
	HWF 10×/∅ 20 mm (with Pointer)	○	○	○	○	OBB-A1448	
Infinity E-Plan objectives	4×/0,10 W.D. 12,1 mm	✓	✓	✓	✓	OBB-A1161	
	10×/0,25 W.D. 2,1 mm	✓	✓	✓	✓	OBB-A1159	
	40×/0,65 (spring) W.D. 0,58 mm	✓	✓	✓	✓	OBB-A1160	
	100×/1,25 (oil) (spring) W.D. 0,19 mm	✓	✓	✓	✓	OBB-A1158	
	Plan 20×/0,40 (spring) W.D. 2,41 mm	○	○	○	○	OBB-A1250	
	Plan 60×/0,80 (spring) W.D. 0,33 mm	○	○	○	○	OBB-A1270	
	Plan 100×/1,15 (water) (spring) W.D. 0,18 mm	○	○	○	○	OBB-A1437	
Binocular tube	<ul style="list-style-type: none"> • Siedentopf 30° inclined/360° rotatable • Interpupillary distance 50–75 mm (for infinity system) • Diopter adjustment: One-sided 	✓	○	✓	○	OBB-A1130	
Trinocular tube	<ul style="list-style-type: none"> • Siedentopf 30° inclined/360° rotatable • Interpupillary distance 50–75 mm • Light distribution 20:80 (for infinity system) • Diopter adjustment: One-sided 	○	✓	○		OBB-A1346	
					✓	OBB-A1549	
Mechanical stage	<ul style="list-style-type: none"> • Stage size W×D 145×130 mm • Travel 76×52 mm • Coaxial coarse and fine focusing knobs, scale: 2 µm • Two slide holder 	✓	✓	✓	✓		
Condenser	Abbe N.A. 1,25 precentered (aperture diaphragm)	✓	✓	✓	✓	OBB-A1103	
Darkfield condenser	N.A. 0,85–0,91 (dry, paraboloid)	○	○	○	○	OBB-A1422	
Illumination	6 V/20 W Halogen spare bulb (transmitted)	✓	✓			OBB-A1370	
	3 W LED illumination system (transmitted) (non-rechargeable)			✓	✓		
Polarising unit	Analyser/Polariser	○	○	○	○	OBB-A1277	
Phase contrast units (including PH-condenser and PH-slides)	Single unit with ∞ PH-Plan objective 10×	○	○	○	○	OBB-A1215	
	Single unit with ∞ PH-Plan objective 20×	○	○	○	○	OBB-A1217	
	Single unit with ∞ PH-Plan objective 40×	○	○	○	○	OBB-A1219	
	Single unit with ∞ PH-Plan objective 100×	○	○	○	○	OBB-A1213	
	If required, there are several magnification levels, please contact our OPTICS product management team						
Fluorescence unit	100 W HBO Epi Fluorescence unit, three-hole slide (B/G) including centering objective	○	○	○	○	OBB-A1154	
	3 W LED Epi Fluorescence unit, three-hole slide (B/G) including centering objective	○	○	○	○	OBB-A1157	
Colour filters for transmitted illumination	Blue (built-in)	✓	✓	✓	✓		
	Green	○	○	○	○	OBB-A1188	
	Yellow	○	○	○	○	OBB-A1165	
	Gray	○	○	○	○	OBB-A1183	
C-Mount	0,47× (focus adjustable)	○	○	○		OBB-A1135	
	0,5× (focus adjustable)				○	OBB-A1515	
	1×		○	○	○		OBB-A1142
						○	OBB-A1514

4 Assembly

4.1 Microscope head

Inside the packaging the microscope head is already mounted but inclined towards the rear. In order to turn it to the front you must loosen the fixing screw on the tube connection point and after the turning fix it again with the screw. In case of removing the head completely from the housing, you should always make sure that you do not touch the lenses with your bare fingers and that no dust enters the apertures.

4.2 Objectives

All four objectives are already mounted to the nosepiece. After removing the protective foil they are ready for use. They are ranged in such a way that if you turn the nosepiece clockwise, the objective with the next higher magnification appears. When the objectives need to be dismounted, you should always make sure that you do not touch the lenses with your bare fingers and that no dust enters the apertures. For objectives which are marked "OIL", you must use an immersion oil with the lowest level of inherent fluorescence.

4.3 Eyepieces

You must always use eyepieces with the same magnification for both eyes. These are simply placed onto the tube connectors, once you have first removed the plastic protective caps. There is no way of fixing them. You should always make sure that you do not touch the lenses with your bare fingers and that no dust enters the apertures.

4.4 Colour filter

A blue colour filter is already an integral part of the microscopes of the series OBF-1 and OBL-1. It is fitted underneath the field diaphragm. In order to use suitable filters, these can simply be placed in the ring bracket of the field lens.

4.5 Condenser

The condenser is firmly fixed onto a holding ring (condenser holder) underneath the microscope stage. The lever for the aperture diaphragm is directed towards the front. There is the ability to adjust the height of the condenser, but not to centre it. We recommend that you use the coarse adjustment knob to bring the specimen stage to its uppermost position when you need to remove the condenser. Then use the focus dial of the condenser to move the condenser holder to a low position. In this way the condenser can be taken off after loosening the screw on the left side of the holding ring. You should avoid touching the optical lenses with bare fingers.

5 Operation

5.1 Getting started

The very first step is to establish a power connection using the mains plug. You should first adjust the **dimmer** to a **low level**, so that when you look through the eyepiece for the first time, your eyes are not immediately subject to a high level of light. You can now switch on the **lighting** using the **main switch**.

The next step is to **place an object holder** with the sample on the angle table. To do this, the cover glass must be facing upwards. You can fix the object holder to the table using the slide holder (*see illustration on the left*). To move the sample into the beam path, you must use the adjustment wheels on the right of the angle table (*see illustration on the right*).

You can position a total of two object holders at the same time.

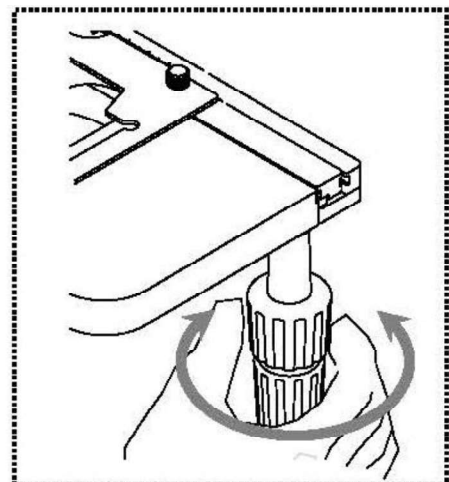
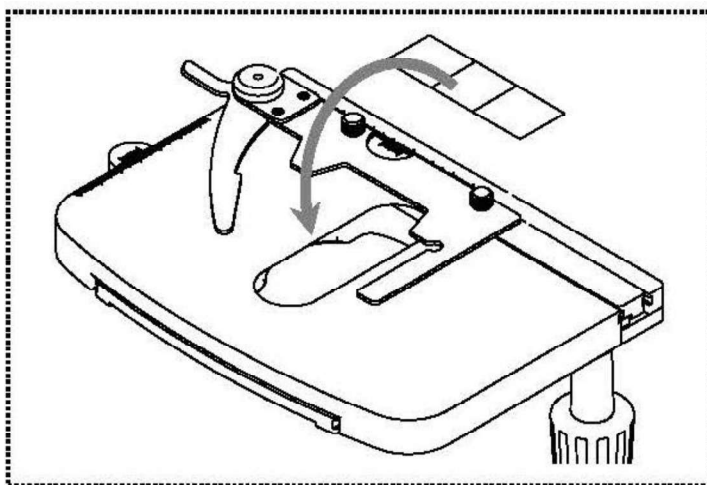

5.2 (Pre-) focussing

When you are observing an object, you must have the correct distance to the objective to achieve a sharp image.

In order to find this distance at the beginning (without other default settings of the microscope) place the objective with the lowest magnification in the beam path, look through the right eyepiece with the right eye and turn it slowly using the coarse adjustment knob (*see illustration*).

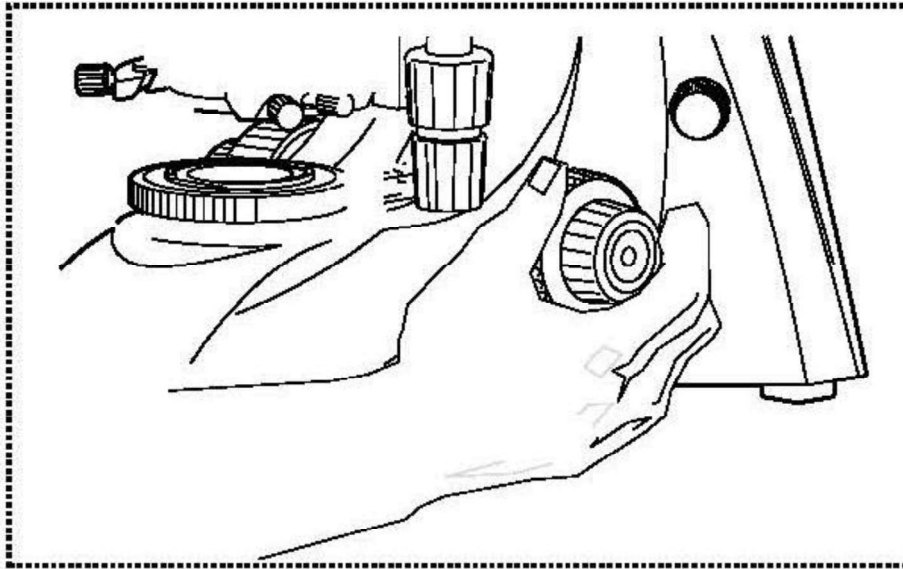

The simplest way of doing this would be to first raise the specimen stage (using the coarse adjustment knob) until it is just under the objective and then lower it slowly. As soon as an image is recognisable (no matter how sharp), then you should only adjust the focus using the fine adjustment knob.

Adjusting the torque of the coarse and fine adjustment knob

Next to the left adjustment wheel for the coarse and fine adjustment knob there is a ring which you can use to alter the torque of these wheels. Turning it in a clockwise direction reduces the torque and turning it in an anti-clockwise direction increases it. On one hand, this function can help to make it easier to adjust the focus and on the other hand it can prevent the specimen stage from slipping down unintentionally.

Important:

In order to avoid damaging to the focussing system, the left and right adjustment wheels for the coarse and fine adjustment knob must never be rotated at the same time in opposite directions.

5.3 Adjusting the interpupillary distance

With binocular viewing, the interpupillary distance must be adjusted accurately for each user, in order to achieve a clear image of the object.

While you are looking through the eyepieces, use your hands to hold the righthand and lefthand tube housing firmly. By pulling them apart or pushing them together, you can either increase or reduce the interpupillary distance (*see illustration*). As soon as the field of views of the lefthand and righthand eyepieces completely overlap each other, i.e. they combine to form a circular image, then the interpupillary distance is set correctly.

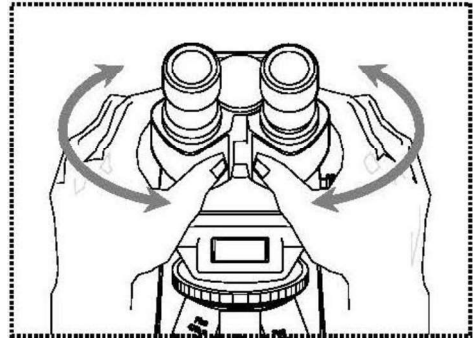

5.4 Dioptre adjustment

The eye strengths of each eye of the microscope user can often be slightly different, which in daily life has no consequences. But when using a microscope this can cause problems in achieving precise focussing.

You can use a mechanism on the left tube connector (dioptre adjustment ring) to compensate for this as follows.

1. Look through the right eyepiece with the right eye and bring the object into focus by using the coarse and fine adjustment knob.
2. Then look through the left eyepiece with the left eye and use the dioptre adjustment ring to focus the image.
To do this, you just need to turn the ring in both directions (*see illustration*), to find out where the image is at its most focussed.

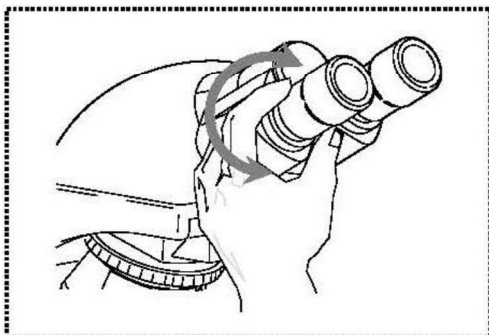

5.5 Adjusting the magnification

After prefocussing has been carried out using the objective with the lowest magnification (see section 5.2), you can then adjust the overall magnification using the nosepiece, as necessary. By turning the nosepiece you can bring any one of the four other objectives into the beam path.

When adjusting the nosepiece, you must take the following points into account:

- The required objective must be properly locked in place at all times.
- The nosepiece should not be rotated by holding individual objectives, you should use the silver ring above the objectives (see illustration).

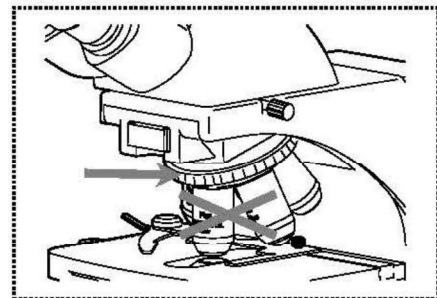

- When rotating the nosepiece you must always make sure that the objective which is about to be positioned in the beam path does not touch the object holder. This can lead to significant damage to the objective lens. We recommend that you always check from the side to make sure that there is sufficient leeway. If this should not be the case, the specimen stage must be lowered accordingly.

If you have focussed the object to be observed for a specific magnification, then if you select the objective with the next greatest magnification, then the object will be slightly out of focus. Use the fine adjustment knob to make a slight adjustment and restore the focus.

5.6 Adjusting the Koehler illumination

To make sure that perfect image results are achieved during microscopic observation, it is important that the direction of light of the microscope is optimised. If, as with the devices in the KERN OBF-1 and OBL-1 series, the lighting can be set in accordance with Koehler, the result is homogenous illumination of the slide and avoidance of disruptive stray light.

The necessary control elements for this are:

- Height-adjustable and centre-adjustable condenser with aperture diaphragm
- Field diaphragm

Note: The condenser of the microscopes of the series OBF-1 and OBL-1 is not centre-adjustable. Therefore it is not a full Koehler illumination. However this is regarded as Fixed-Koehler, since the condenser is pre-centred.

When adjusting the Koehler lighting for the first time, you must first select the lowest possible objective magnification, so that you can carry out the following steps.

1. Use the condenser focus wheel to position the condenser directly below the specimen stage. Switch on the lighting and use the coarse and fine adjustment knob to bring the slide with the cover glass positioned facing upwards into focus.

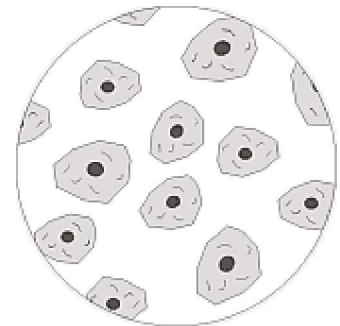

2. Close the field diaphragm completely using its adjusting ring. When you look in the microscope a blurred image appears in the aperture.

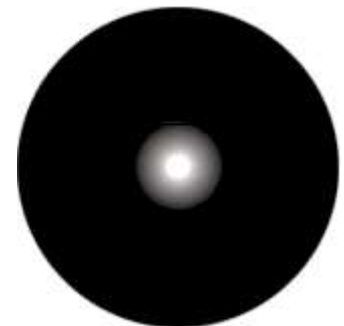

3. Adjust the height of the condenser until the image from the field diaphragm appears clearly in the field of view. For some microscopes there is a risk that you will lift the condenser up so high that it collides with the object holder. Therefore care is needed when doing this.

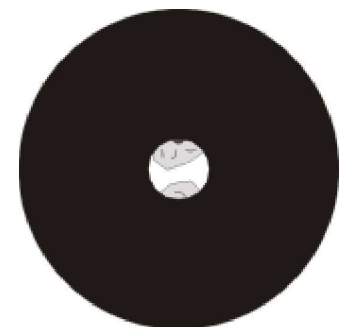

4. Open the field diaphragm until it just disappears out of the field of view.
If necessary, simply re-centre using the centring screws on the condenser holder.

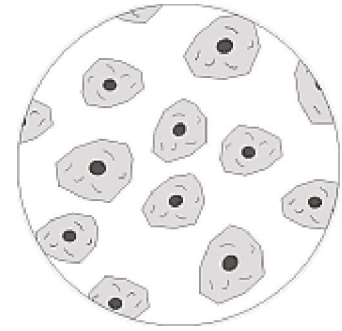

5. Use the aperture diaphragm of the condenser to find the very best compromise between contrast and resolution for the microscopic image. The scale divisions on the condenser can be used as a guideline. Select in accordance with the objective being used.

The view in the tube without the eyepiece should look something like the illustration on the right.

The diameter of the aperture diaphragm which is then visible should make up approximately $\frac{2}{3}$ of the pupil diameter.

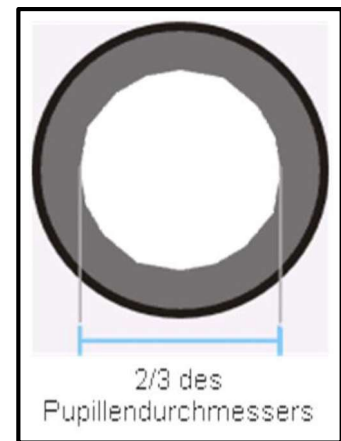

If the eyepiece should be removed, for checking, then please make sure that no dirt or dust falls into the tube.

6. It is possible to alter the brightness of the bulb using the **dimmer**. The brightness is always controlled by the bulb brightness and not by the aperture diaphragm.
7. Possibly there is the need of re-adjusting the focus and x-y axis.
8. Observe the object.

If another magnification is selected afterwards, then the Koehler illumination does not have to be reset from scratch, only the aperture diaphragm and field diaphragm need to be adjusted as required.

5.7 Using eye cups

The eye cups supplied with the microscope can basically be used at all times, as they screen out intrusive light, which is reflected from light sources from the environment onto the eyepiece, and the result is better image quality.

But primarily, if eyepieces with a high eye point (particularly suitable for those who wear glasses) are used, then it may also be useful for users who don't wear glasses, to fit the eye cups to the eyepieces.

These special eyepieces are also called High Eye Point eyepieces. They can be identified by the glasses symbol on the side. They are also marked in the item description by an additional "H" (example: HSWF 10x Ø 23 mm).

When fitting the eye cups, make sure that the dioptre setting is not moved. We would therefore advise that you hold the dioptre compensation ring on an eyepiece with one hand while you fit the eye cup with the other.

Before using the microscope, users who wear glasses must remove the eye cups, which you may find on High Eye Point eyepieces.

As the eye cups are made of rubber, you must be aware that when you are using them, they can become slightly dirty through grease residues. In order to maintain hygiene, we would therefore recommend that you clean the eye cups regularly (e.g. with a damp cloth).



Eye cups



High Eye Point eyepiece
(identified by the glasses symbol)

5.8 Using oil immersion objectives

The 100x objectives of the OBF-1 and OBL-1 series are objectives which can be used with oil immersion (they are always marked with the word "OIL"). Using these generates a particularly high resolution for microscopic images.

To use oil immersion correctly, please follow these steps.

1. Put a drop of oil on the cover glass (with standard thickness of 0.17 mm) of the object slide.
2. Lower the specimen stage and position the 100x objective in the beam path.
3. Bring the specimen stage or object slide to the objective very slowly until there is slight contact.
4. Observe the object.

The object slide and objective must not be pressed against each other. The oil constitutes the contact layer.

If the contact is made too jerky, there is a chance that existing air bubbles in the oil cannot escape. This would have a negative impact on image clarity.

After use or before changing the slide, any components which have been in contact with the oil must be cleaned thoroughly. *See also 1.4 Maintenance and cleaning.*

6 Changing the bulb

Halogen

You must not attempt to change the bulb immediately after the microscope has been used, as the bulb will still be hot and so there is a risk that the user could be burnt. Before changing the bulb the device must be switched off and unplugged.

To change the bulb, tip the device carefully to the back or side. When doing this, please make sure that all microscope components are firmly fixed. The bulb holder is on the underside of the device. It can be opened by undoing the screws on the holder (see *left illustration*). We recommend that here you should also test again, to check that heat is no longer being produced. The defective bulb can be pulled out of the socket and be replaced with a new one. After the bulb holder has been replaced in the underside of the device and the screws replaced, the bulb replacement procedure is complete.

Important:

When fitting the new bulb into the socket, it must only be handled with sterile gloves or using the bulb packaging film. Grease and dust residue can have a negative effect on the light quality and service life.

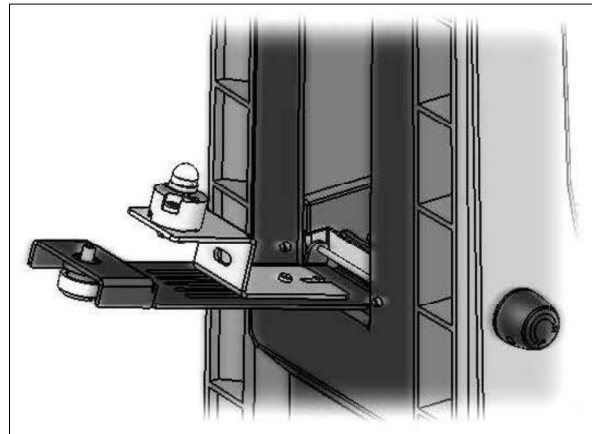
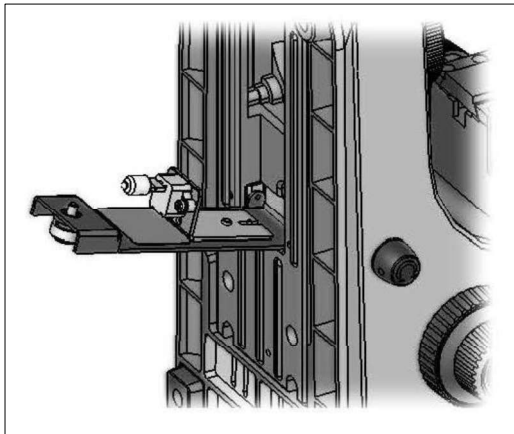

LED

Before changing the bulb the device must be switched off and unplugged.

To change the bulb, tip the device carefully to the back or side. When doing this, please make sure that all microscope components are firmly fixed. The bulb holder is on the underside of the device. It can be opened by undoing the screws on the holder (see *right illustration*). The defective LED module can be removed by loosening the two screws fixing the module and unraveling the connection point of its cable. Now the new module has to be mounted in the same way as the original one. After the bulb holder has been replaced in the underside of the device and the screws replaced, the bulb replacement procedure is complete.

7 Changing the fuse

The fuse housing is on the rear of the microscope below the mains power supply socket. With the device switched off and unplugged, you can pull out the housing. When doing this, it is helpful to use a screwdriver or similar tool. The defective fuse can be removed from its housing and be replaced with a new one.

After that, you just need to insert the fuse housing back into the insertion point below the mains power supply socket.

8 Using optional accessories

8.1 Polarisation unit

The polarisation unit consists of a polariser and an analyser.

Both consist of a round glass plate with an external holder ring. To mount the analyser you have to remove the microscope head at first. Then the analyser has to be inserted into the round aperture of the beam path right above the nose piece.

The polariser on the other hand is only placed on the ring holder of the field lens (see *right illustration*).

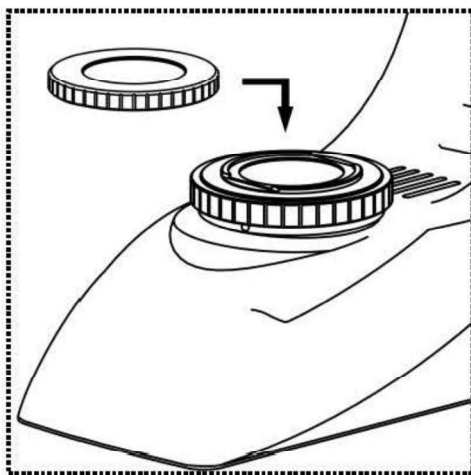

There are two points to take into account when subsequently using the polarisation unit:

- The aperture setting of the condenser must be in position **PH**.
- For its starting position, the polariser must be turned to the position in which you can see the highest level of darkness in the field of view (without object slide).

8.2 Camera connection

OBF 131, OBF 132, OBF 133, OBL 135, OBL 137

Due to the trinocular tube, which is a standard fitting for the models of the series OBF-13 and OBL-13, it is possible to connect microscope cameras to the device, in order to digitally record images or sequences of images of an object being observed.

After the plastic cover has been removed from the camera adapter connector on the top of the microscope head, then a suitable adapter must be fitted.

In general there are two C-mount adapters available for this (1x and 0.47x magnification, *see Chapter 3 Features*). After fitting one of these adapters it can be fixed with the fixing screw. A camera which has a C-mount thread is then screwed on top of the adapter.

We recommend that you first adjust the field of view using the eyepieces on the device for the existing requirements, and then carry out the observation using the microscope camera (i.e. using the PC screen which is connected).

The tube has a light distribution that guarantees the providing of light for the eyepieces and the camera connection at the same time. This means that it is possible to simultaneously observe by the eyepieces and PC screen.

For C-mount adapters, which have their own integrated magnification, the image which is shown on the camera connected to the device can often have a different level of focus compared with the image on the eyepiece.

In order to be able to bring both images into focus, the focus can be adjusted by those adapters.

8.3 Dark field units

There is the following way to carry out dark field applications.

1. A special dark field condenser can be used in place of the standard condenser. This as a paraboloid construction and also meets the requirements of professional application fields, in contrast to a dark field attachment.

8.4 Phase-contrast unit

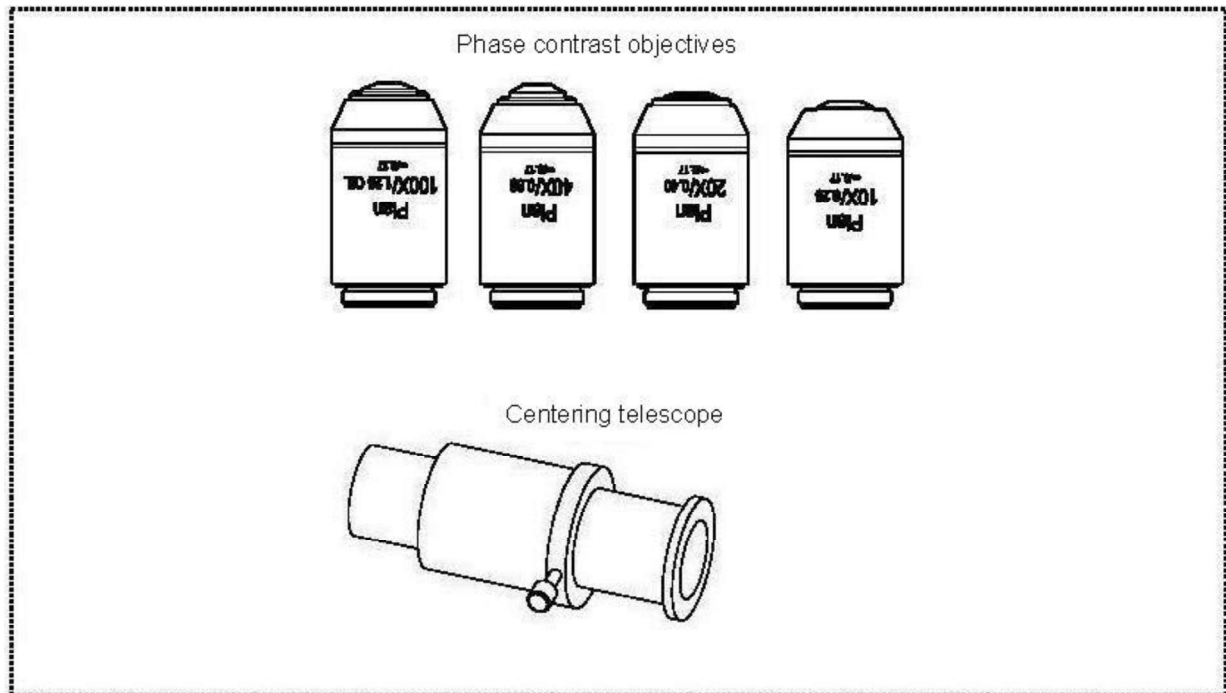

Simple phase-contrast unit

This consists of a simple PH condenser, a PH objective with a specific magnification (10x, 20x, 40x or 100x), a PH slider, which is adapted to the lens being used, a centering telescope and a green filter.

To use this, you need to replace the standard condenser of the microscope with the PH condenser. One of the objectives in the nosepiece is also replaced with the PH objective and this is positioned in the beam path.

With the surface marked with the magnification information facing up, the PH slider is pushed into the insertion point on the PH condenser until stop. At this position the phase ring of the PH slider is in the beam path and the phase-contrast application can begin. In order to return to the bright field application, you must pull the PH slider out of the condenser, so that the beam can pass the condenser without being affected by the PH slider.

The PH objective has a PH ring in its lens system, just like the PH slider. Due to their size on one hand and their positioning on the other, these two rings must be aligned to one another in the beam path. The position of the ring in the objective cannot be altered, that of the ring in the slider however can be. Before starting the phase-contrast application you have to check if this alignment is given. For this you must install the centring telescope to the tube connector instead of a standard eye piece and look through it (*The appearing image can be focussed by firstly loosening the locking screw on the centring telescope, pull out the front part of the centring telescope to the correct position and finally retightening the locking screw*).

When installing the centring telescope instead of one of the eyepieces there is appearing an image of a white (slide) and a black (objective) ring in the field of view (*see illustration*). The black one is located centrally and the white one possibly shifted to the side. In case of a shift, the position of the white ring has to be adjusted in order to effect an exact overlapping of both rings by means of the two adjusting screws of the condenser.

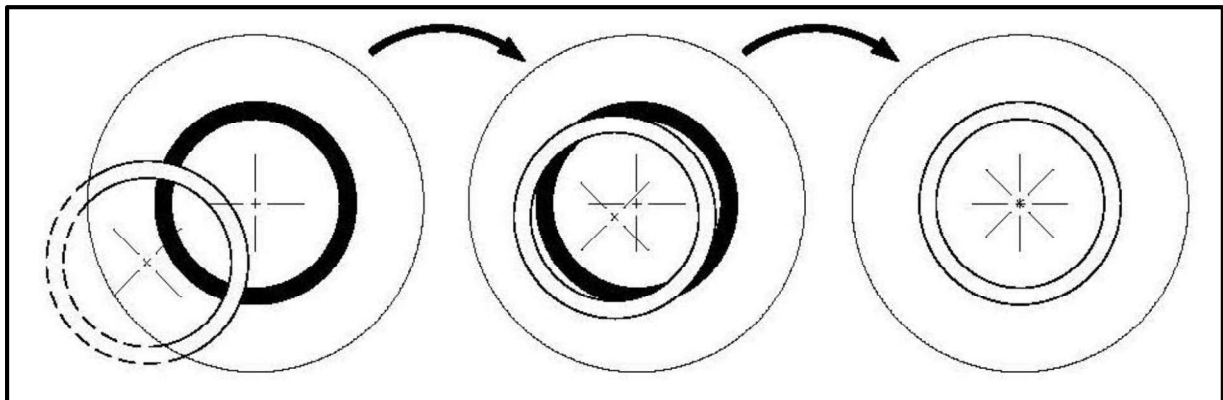

Depending on the preferences of the user, using a green filter can produce a more effective and pleasant image. To achieve this, the green filter must be placed in the ring bracket of the field lens.

8.5 Fluorescence reflected light unit

OBL-1

There are samples, which can be excited by light beams and thereby show emissions, which have different wave lengths than the previous excitation beams. The wave length of the emission is always bigger than the wave length of the excitation (Stokes shift). This process is called fluorescence and can serve as the base of a microscopic contrasting method. For the most common way to realise this, an upright light microscope is extended by a fluorescence reflected light unit.

Principle

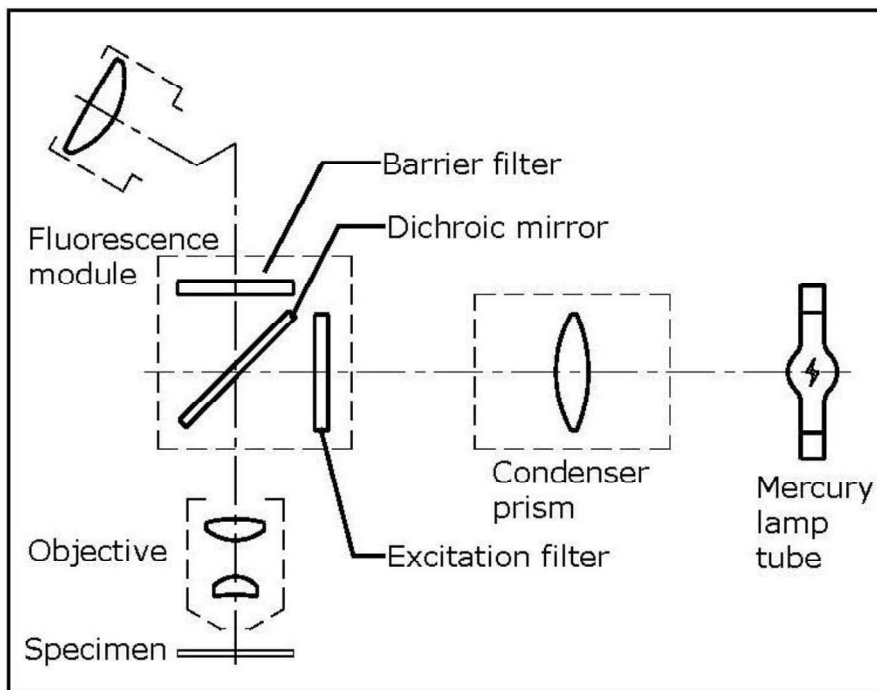

Depending on the sample there is an excitation light needed, that is contained in the spectrum of the light source (HBO or LED). The excitation filter is only permeable for the according wave length. After that the excitation light hits a dichroic mirror, which reflects it towards the objective and the sample. After the sample absorbed the excitation light, the emission of the fluorescent light occurs (with a bigger wave length than the excitation light). The part of the fluorescent light, which is beamed into the objective, can pass the dichroic mirror. The dichroic mirror additionally prevents the remaining part of the excitation light from advancing towards the eyepieces. The barrier filter finally eliminates all wave ranges out of the beam path not belonging to the observed fluorescence. Thus the resulting image is just developed by the fluorescent light emitted from the sample.

Overview of wave lengths for excitation and emission per excitation filter

UV	Wavelength range for excitation:	330-380nm
	Wavelength range for emission:	435nm
V	Wavelength range for excitation:	380-420nm
	Wavelength range for emission:	460nm
B	Wavelength range for excitation:	420-490nm
	Wavelength range for emission:	520nm
G	Wavelength range for excitation:	500-550nm
	Wavelength range for emission:	590nm

Blue line: Wave length excitation
Green line: Wave length emission

U:

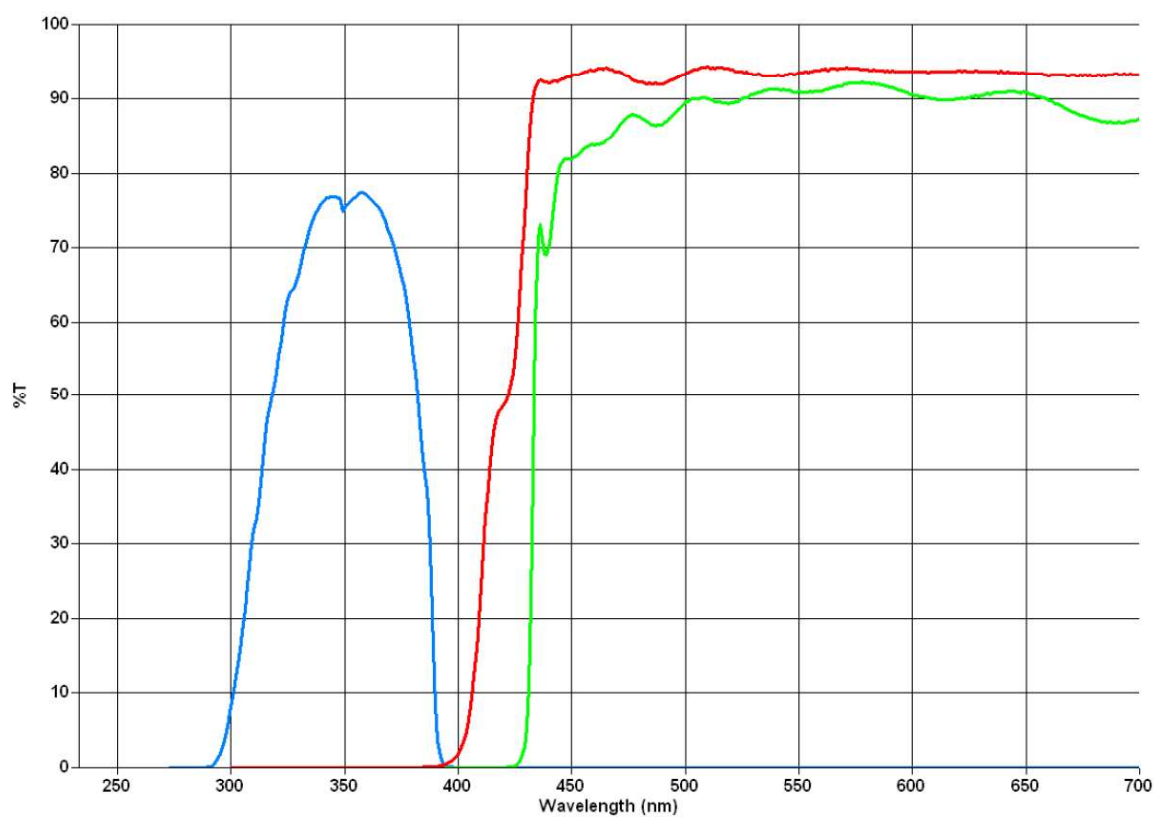

V:

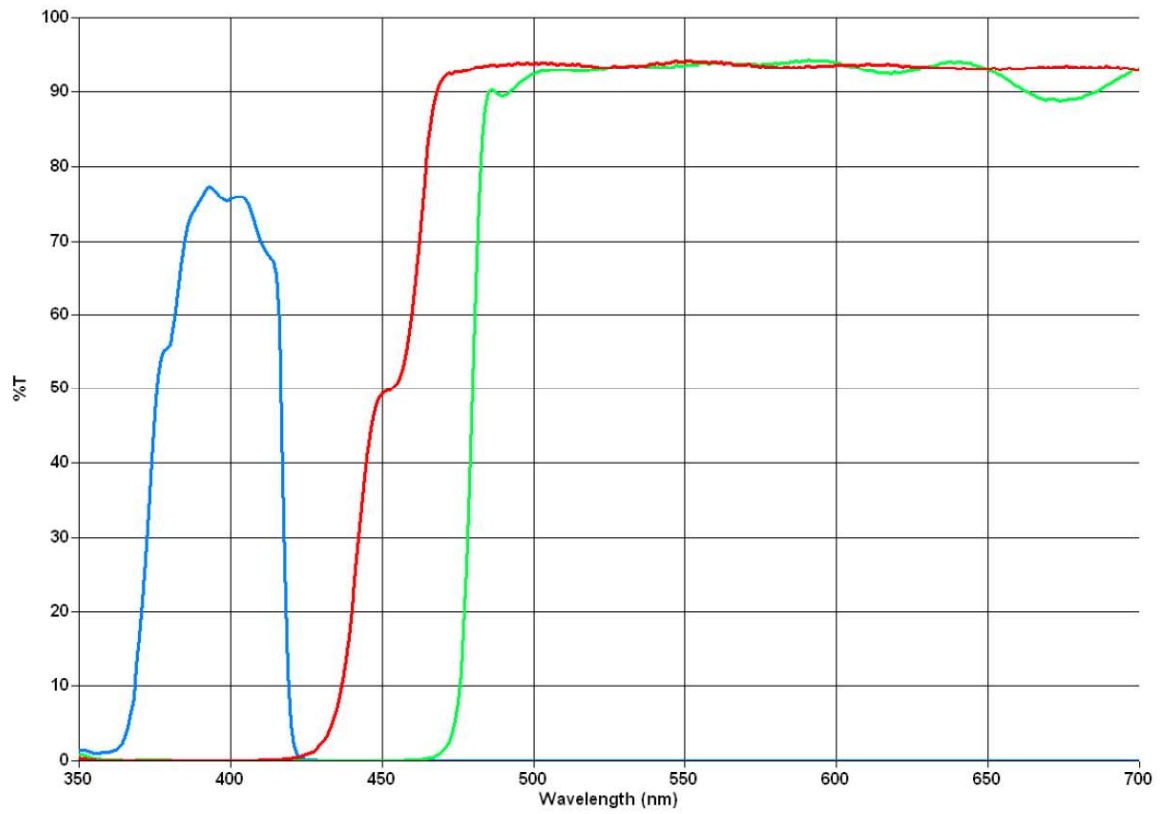

B:

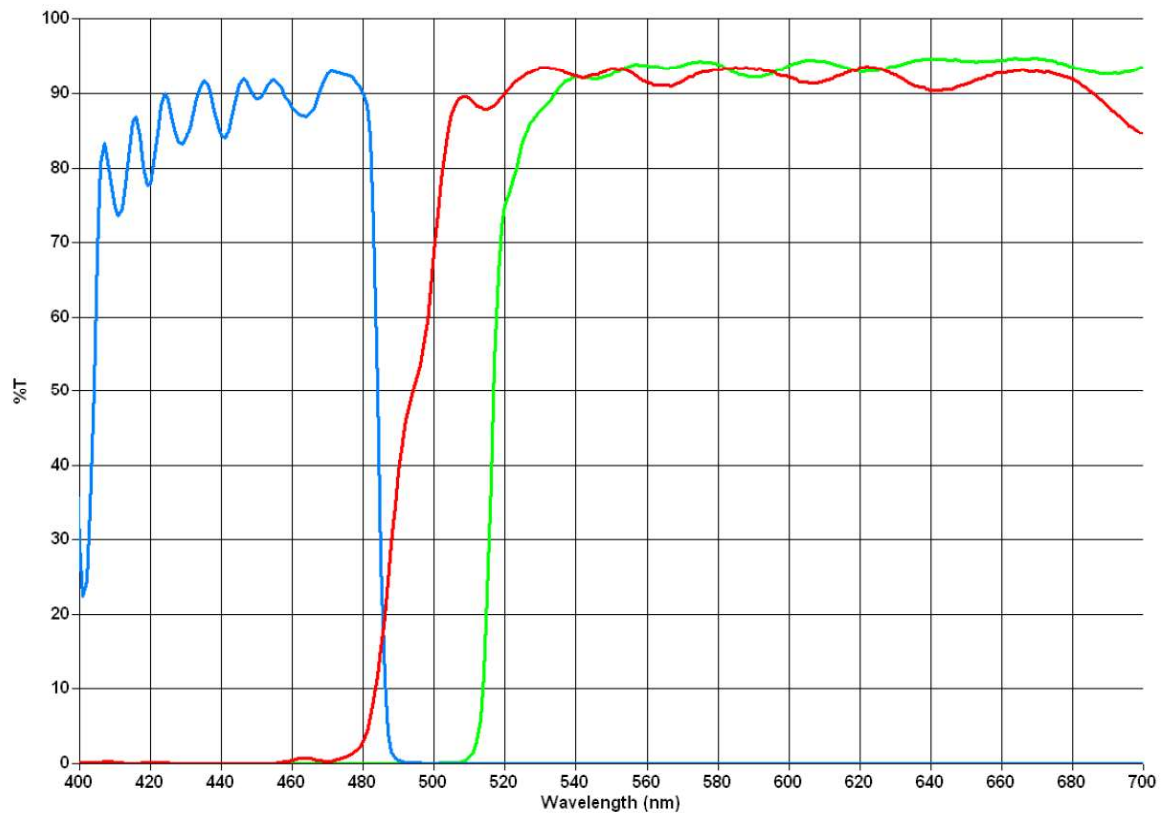

G:

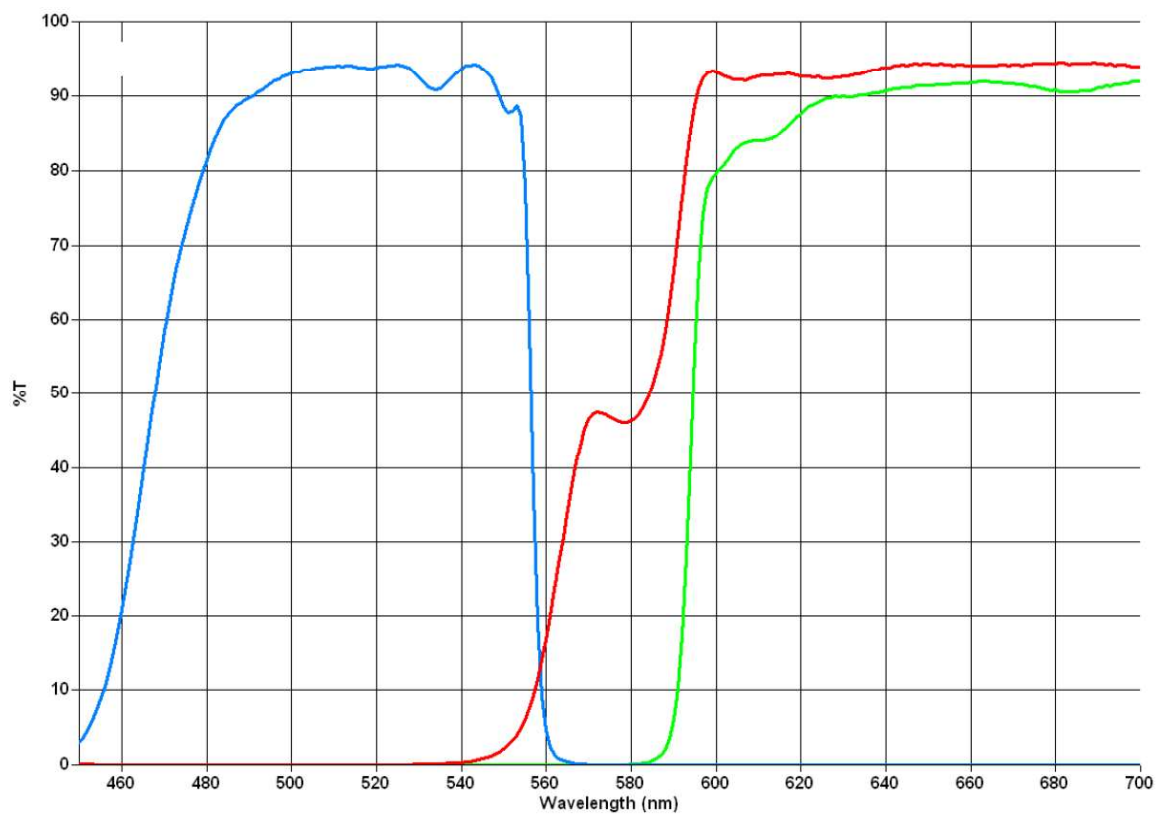

Nomenclature (components)

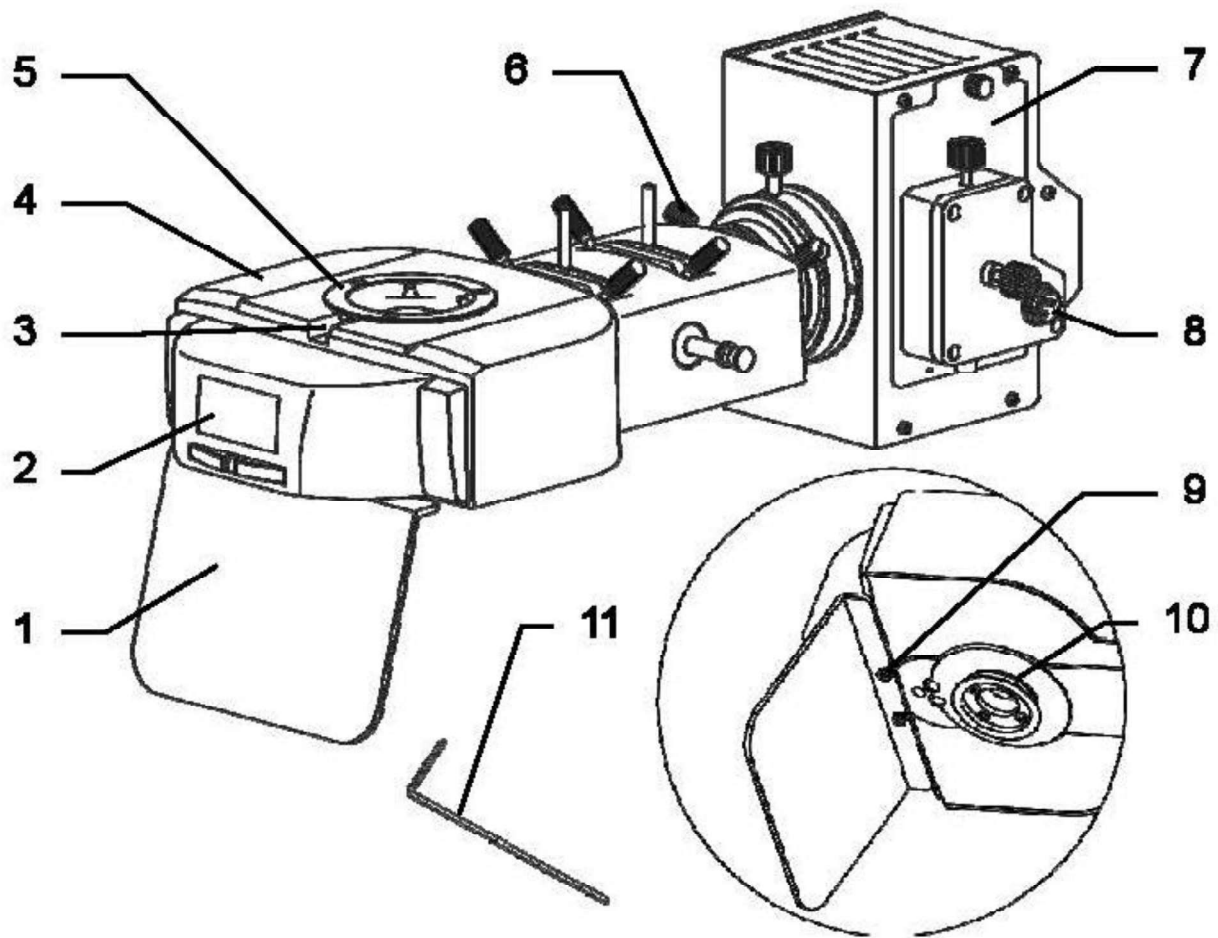

- 1 Protective plate
- 2 Cover for FL module
- 3 Fixing Allen screw for microscope head
- 4 Main body
- 5 Connection point for microscope head
- 6 Fixing screw for lamp housing

- 7 HBO/LED lamp housing
- 8 Power connection
- 9 Screw for attaching the protective plate
- 10 Connection point for microscope housing
- 11 Allen wrench

Nomenclature (control elements)

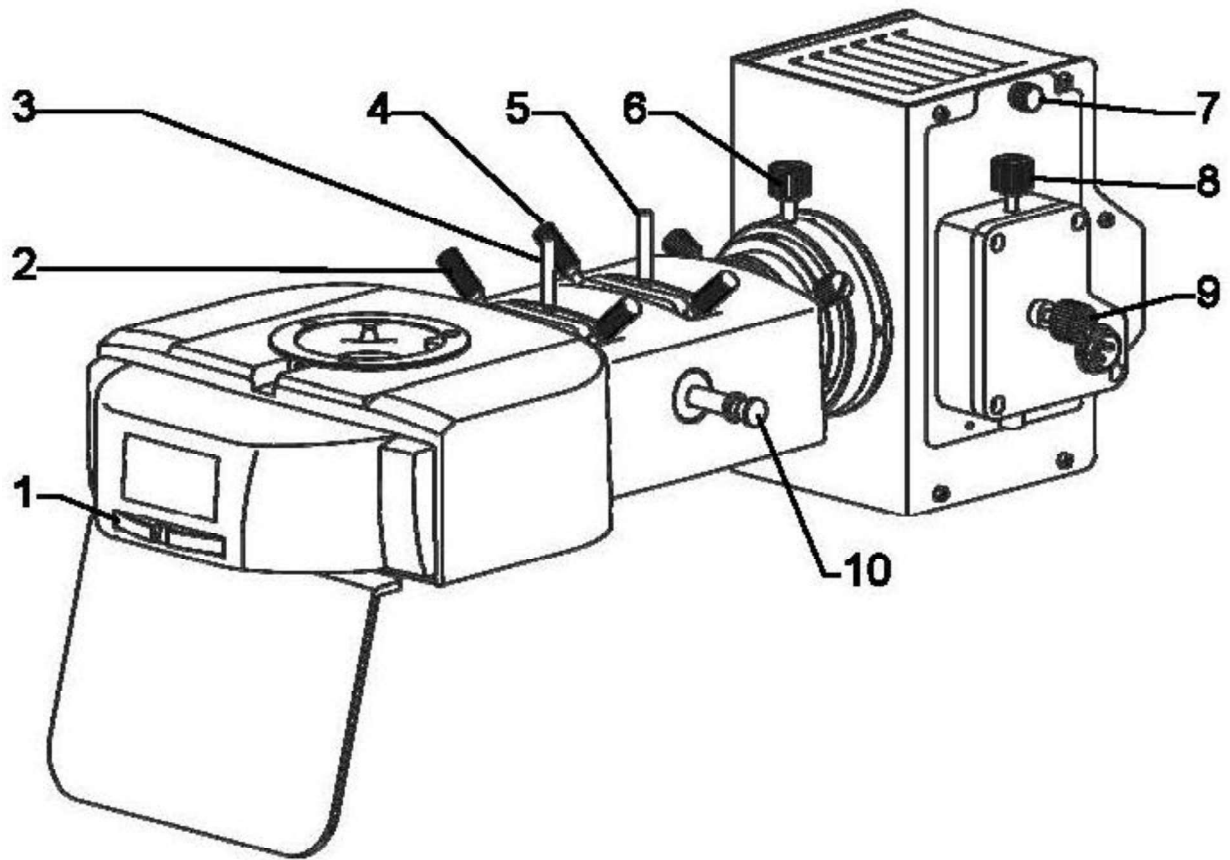

- | | | | |
|---|--|----|--------------------------------------|
| 1 | Control wheel for FL module | 6 | Condenser control |
| 2 | Centring device for field diaphragm | 7 | Screw for cover of lamp housing |
| 3 | Control lever for field diaphragm | 8 | Centring screw for lamp (vertical) |
| 4 | Centring device for aperture diaphragm | 9 | Centring screw for lamp (horizontal) |
| 5 | Control lever for aperture diaphragm | 10 | Control lever for illumination |

Nomenclature (Power supply unit for HBO lamp)

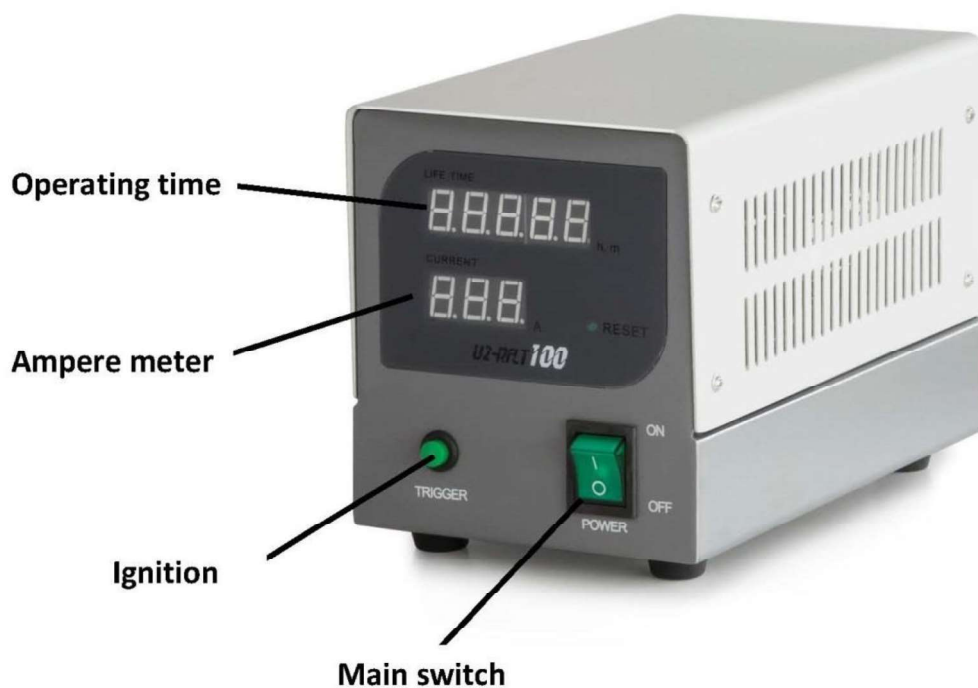

Basic data

There are two different fluorescence reflected light units available for the microscopes of the series OBL-1. They have the following specifications.

Article number	Illumination	Excitation filter	Centring objective	Input voltage power supply unit
OBB-A1154	100W HBO	B / G	Yes	100-240V
OBB-A1157	3W LED	B / G	Yes	100-240V

Assembly

In order to assemble the fluorescence reflected light unit correctly and mount it afterwards to the microscope housing, the following steps have to be carried out.

1. When the microscope is already assembled without the FL unit, you have to remove the microscope head at first.
2. Tip the main body of the FL unit to the side and mount the protective plate to the appropriate location on the underside.
3. Attach the main body to the therefore intended connection point of the microscope housing and fix it with the screw.
4. Unite the lamp housing and the main body by their connection points and fix it with both screws.
5. Attach the microscope head to the main body and fix it with the Allen screw.
6. Install the connecting cable between lamp housing and power supply unit.
7. Establish the power supply by attaching the mains cable.

Operation

Before you use the reflected light unit for special fluorescence applications, it will be favourable to adjust the microscope in the bright field mode. This includes the placing of the sample, adjusting the interpupillary distance, pre-focussing, dioptr adjustment, etc. After that you can go on with the usage of the fluorescence reflected light unit.

1. When using a HBO lamp at first there must be ensured, that the control lever for the illumination is slid-in.
2. Establish the power supply. When using a HBO lamp, check the setting of the input voltage by using the appropriate slide on the rear of the power supply unit (100V/240V).
3. Press the main switch. When using a HBO lamp, you have to press the ignition after that in order to illuminate the lamp. It lasts about 15 minutes until the lamp has gained a maximum and stable illuminating power.
4. After placing the sample you can bring the needed objective into the beam path.
5. Choose the right position of the control wheel for the FL module.
6. When using a HBO lamp, now the control lever for the illumination can be pulled out.
7. Start the observation.

Control elements for illumination

The following control elements for the illumination play a role within the fluorescence microscopy:

- Field diaphragm, aperture diaphragm, condenser:
Optimisation of the contrast and the light yield.
- Control lever for illumination:
When located at the medium position there is a filter, which softens the lighting, so that samples, which are not stable enough for the full illuminating power, can be observed as well.



Important warnings for the usage of a HBO lamp

- During operation the lamp is showing a strong heat development. It should be avoided to come into contact with the lamp housing while and after some time of running the reflected light unit.
- The lamp must not in any circumstances be switched off during the pre-heating. It could cause a significant reduction of the lamps life time.
- Equally the lamp must not be switched on directly after a switch-off process.
- When pausing the observation you should always slide in the control lever for the illumination in order to interrupt the light beam. The light spectrum of the HBO lamp often can be harmful for microbes.
- Never look inside the eyepieces when the beam path is opened (by the control lever for illumination) and there is set an empty position of the FL module at the same time. There is the risk of blinding.
- A HBO lamp has a certain life time. The closer you push it to its limit, the bigger the risk of an explosion of the lamp and setting free of toxic mercury vapour. This must be avoided at all costs.

The following devices can provide information about the necessity of a lamp replacement (This applies for 100W HBO lamps):

- Ampere meter on the power supply unit
As soon as 4.8 A are reached → lamp replacement
- Life time display on the power supply unit
As soon as 100 h are reached → lamp replacement

Centring the lamp (HBO)

When running the HBO lamp for a long time there is the possibility, that the holder of the lamp is moving out of its centre due to the strong heat development. This circumstance has to be corrected when it appears, because therefore the field of view is no longer equally illuminated.

1. Screw in the centring objective on the nosepiece instead of a standard objective.
2. Position the centring objective into the beam path.
3. Set FL module to position G (for this setting there is a relatively subdued light, convenient for the eyes).
4. When looking into the eyepieces, there is appearing a hair cross and the decentred light spot (also in cross shape).
5. Use the two centring screws on the lamp housing for moving the light spot into the centre of the hair cross. (Warning: Heat development on the lamp housing).

Changing the lamp (HBO)

1. Disconnect the FL reflected light unit from the power supply.
2. Check if the lamp housing has cooled down.
3. Loosen the screw for the cover of the lamp housing (only when it is cool).
4. Carefully flip out the lamp holder.
5. Loosen the two fixing screws for the HBO lamp.
6. Replace the old lamp by a new one.
7. Tighten the fixing screws again.
8. Close the cover and fix it with the screw.

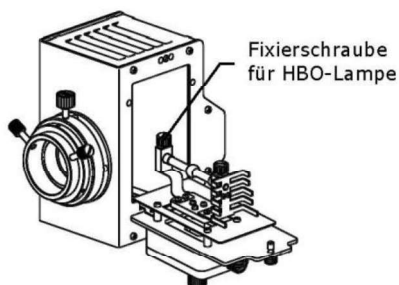

The new installed spare lamp may under no circumstances be touched with naked hands. Impurities will benefit the risk of explosion during operation.

If there should be nevertheless impurities, the lamp has to be cleaned. We recommend for this purpose to use a lint-free cloth soaked with an ether alcohol mixture (Proportion: 70/30).

Changing the fuse

The fuse housing is on the rear of the power supply unit next to the mains power supply socket. With the device switched off and unplugged, you can screw out the housing. The defective fuse can be removed from its housing and be replaced with a new one.

After that, you just need to insert the fuse housing back into the insertion point next to the mains power supply socket.

9 Trouble shooting

Problem	Possible causes
The bulb does not light	The mains plug is not correctly plugged in
	There is no power at the socket
	Defective bulb
	Defective fuse
The bulb blows immediately	The specified bulb or fuse has not been used
The field of view is dark	The aperture diaphragm and/or field diaphragm are not opened wide enough
	The selector switch for the beam path is set to "Camera"
	The condenser is not correctly centred
You cannot adjust the brightness	The brightness control has been set incorrectly
	The condenser has not been correctly centred
	The condenser is too low
The field of view is dark or is not correctly illuminated	The objective is not positioned correctly on the beam path
	The selector switch for the beam path is between two settings
	The nosepiece is not correctly fitted
	The condenser is not correctly fitted
	An objective is being used which doesn't match the lighting area of the condenser
	The condenser has not been correctly centred
	The field diaphragm is closed too tightly
	The bulb is not correctly fitted
The field of view of one eye does not match that of the other eye	The interpupillary distance is not correctly adjusted
	Dioptre setting has not been carried out correctly
	Different eyepieces are used for the righthand and lefthand side
	The eyes are not used to using a microscope

Problem	Possible causes
Blurred details Bad image Bad contrast Vignetted field of view	The aperture diaphragm is not opened wide enough
	The condenser is too low
	The objective does not belong to this microscope
	The front lens of the objective is dirty
	An immersion object has been used without immersion oil
	The immersion oil contains air bubbles
	The condenser is not correctly centred
	The recommended immersion oil has not been used
Dirt or dust in the field of view	Dirt / dust on the objective
	Dirt /dust on the front lens of the condenser
	Dirt / dust on the eyepieces
One side of the image is blurred	Dirt / dust on the front lens of the condenser
	Dirt / dust on the object
	The stage was not correctly fitted
	The objective is not positioned correctly on the beam path
The image flickers	The nosepiece is not correctly fitted
	The objective is not positioned correctly on the beam path
	The condenser has not been correctly centred
The coarse adjustment knob is difficult to turn	The rotational resistance brake is too tight
	The angle table is blocked by a solid body
The stage moves down on its own The fine adjustment knob moves on its own	The rotational resistance brake is not tight enough
When you move the table, the image becomes blurred	The stage was not correctly fitted

10 Service

If, after studying the user manual, you still have questions about commissioning or using the microscope, or if unforeseen problems should arise, please get in touch with your dealer. The device may only be opened by trained service engineers who have been authorised by KERN.

11 Disposal

The packaging is made of environmentally-friendly materials, which you can dispose of at your local recycling centre. Disposal of the storage box and device must be carried out by the operator in accordance with all national or regional laws in force in the location of use.

12 Further information

The illustrations may differ slightly from the product.

The descriptions and illustrations in this user manual are **subject to change without notice. Further developments** on the device may lead to these changes.



All language versions contain a non-binding translation.
The original German document is the binding version.